

Tachogenerators

Blind hollow shaft $\varnothing 12-16$ mm or cone shaft $\varnothing 17$ mm (1:10)

Housing $\varnothing 95$ mm, bearingless configuration

GTB 9



GTB 9

Features

- Low response time
- Open circuit voltage 10...60 mV per rpm
- Blind hollow shaft $\varnothing 12-16$ mm or cone shaft $\varnothing 17$ mm (1:10)
- High signal quality due to patented LongLife technology
- High protection IP 68
- Connector output
- No auxiliary energy source required

Technical data - electrical ratings

Reversal tolerance	≤ 0.1 %
Linearity tolerance	≤ 0.15 %
Temperature coefficient	± 0.05 %/K (open-circuit)
Isolation class	B
Calibration tolerance	± 5 %
Climatic test	Humid heat, constant (IEC 60068-2-3, Ca)
Performance	0.3 W (speed ≥ 5000 rpm)
Armature-circuit time-constant	< 9 μ s
Interference immunity	EN 61000-6-2
Emitted interference	EN 61000-6-3
Approval	CE

GTB 9.06

Open-circuit voltage	10...20 mV per rpm
----------------------	--------------------

GTB 9.16

Open-circuit voltage	60 mV per rpm
----------------------	---------------

Technical data - mechanical design

Size (flange)	$\varnothing 95$ mm
Shaft type	$\varnothing 12...16$ mm (blind hollow shaft) $\varnothing 17$ mm (cone shaft 1:10)
Protection DIN EN 60529	IP 68
Torque	0.35 Ncm
Rotor moment of inertia	0.95 kgcm ²
Materials	Housing: stainless steel / plastic Shaft: stainless steel
Operating temperature	-30...+130 °C
Resistance	IEC 60068-2-6 Vibration 10 g, 10-2000 Hz IEC 60068-2-27 Shock 100 g, 6 ms
Weight approx.	0.7 kg
Connection	Connector

Tachogenerators

Blind hollow shaft $\varnothing 12-16$ mm or cone shaft $\varnothing 17$ mm (1:10)

Housing $\varnothing 95$ mm, bearingless configuration

GTB 9

Part number

GTB9.06L/4

GTB9.16L/4 60

Design

- Cylindrical shaft
- K Cone shaft

Design

- Cylindrical shaft
- K Cone shaft

Open-circuit voltage

10 10 mV per rpm
20 20 mV per rpm

Open-circuit voltage

60 60 mV per rpm

Data according to type

Type	Off-load voltage U_0 [mV/rpm]	Minimum load required depending on speed range [rpm]			Maximum operating speed n_{max} [rpm]	Armature resistance $R_A(20^\circ C)$ [Ω]	Armature inductance L_A [mH]
		0-3000	0-6000	0- n_{max}			
GTB9.06L/410	10	≥ 5	≥ 12	≥ 27	9000	105	40
GTB9.06L/420	20	≥ 20	≥ 48	≥ 108	9000	370	169
GTB9.16L/460	60	≥ 60	≥ 144	-	6000	340	275

Superimposed ripple (for $\tau_{RC} = 0.3$ ms): $\leq 0.5\%$ (peak-peak) $\leq 0.25\%$ (rms)

Replacement switching diagram

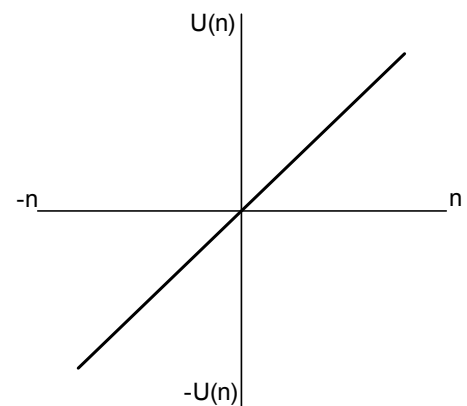
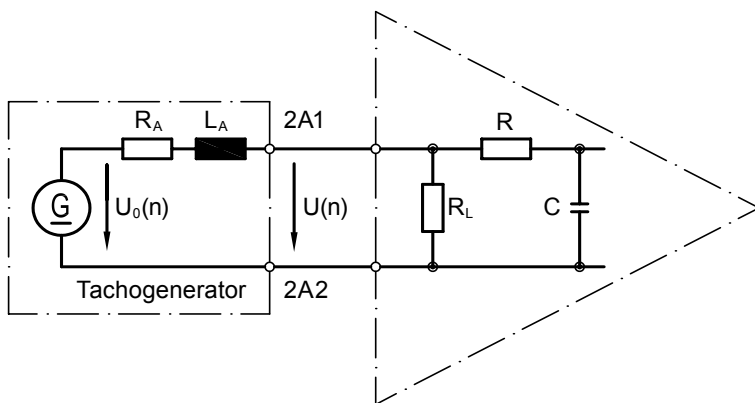

$$\tau_{RC} \approx R \cdot C \quad \tau_A \approx \frac{L_A}{R_L}$$

$$U(n) = U_0(n) \frac{R_L}{R_A + R_L} \approx U_0(n) \text{ for } R > R_L \gg R_A$$

Polarity for positive rotating direction: 2A1: + 2A2: - (VDE)

Tachogenerators

Blind hollow shaft $\varnothing 12-16$ mm or cone shaft $\varnothing 17$ mm (1:10)

Housing $\varnothing 95$ mm, bearingless configuration

GTB 9

Terminal assignment

View A - Connecting terminal

Polarity for positive direction of rotation

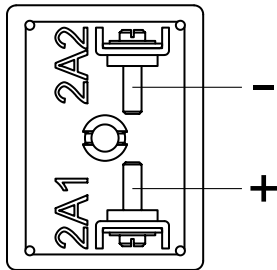

Accessories

Mounting cone

Carbon brushes

Tachogenerators

Blind hollow shaft $\varnothing 12-16$ mm or cone shaft $\varnothing 17$ mm (1:10)

Housing $\varnothing 95$ mm, bearingless configuration

GTB 9

Dimensions

GTB 9.06 - cylinder shaft design

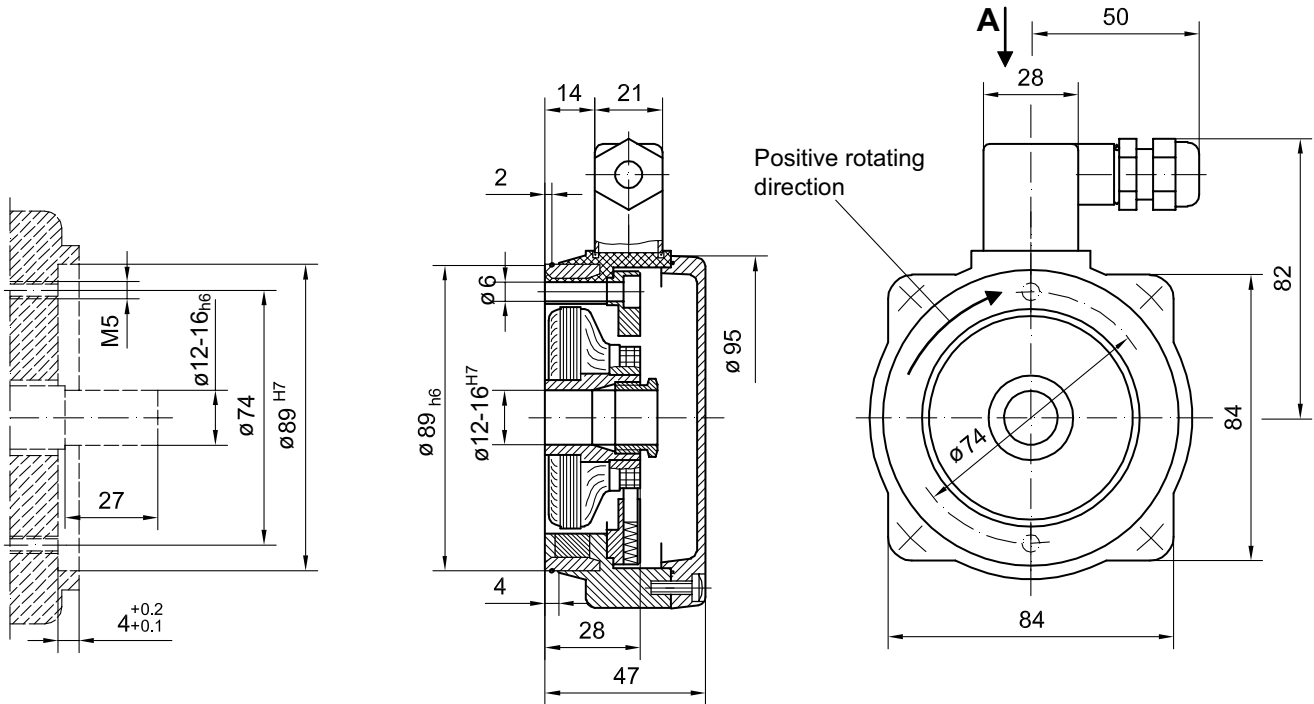

HM85M20491

GTB 9.06 K - cone shaft design

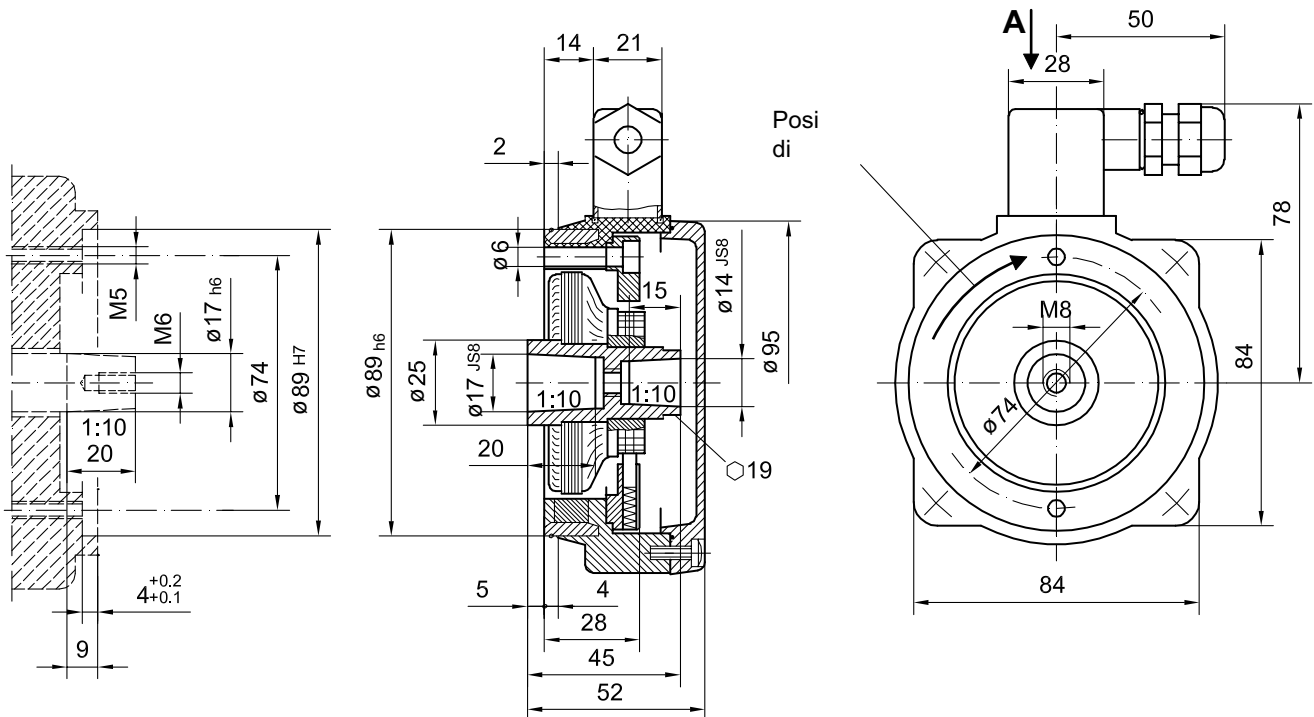

HM85M20484